An Introduction to Electrical Generators for Power Plants

Course No: D02-004

Credit: 2 PDH

J. Paul Guyer, P.E., R.A., Fellow ASCE, Fellow AEI



Continuing Education and Development, Inc.
22 Stonewall Court
Woodcliff Lake, NJ 07677

P: (877) 322-5800
info@cedengineering.com

An Introduction to Electrical Generators for Power Plants



J. Paul Guyer, P.E., R.A.

Paul Guyer is a registered civil engineer, mechanical engineer, fire protection engineer and architect with 35 years experience designing buildings and related infrastructure. For an additional 9 years he was a principal staff advisor to the California Legislature on capital outlay and infrastructure issues. He is a graduate of Stanford University and has held numerous national, state and local offices with the American Society of Civil Engineers, Architectural Engineering Institute and National Society of Professional Engineers.

CONTENTS

1. TYPICAL VOLTAGE RATINGS AND SYSTEMS
2. GENERATORS
3. GENERATOR LEADS AND SWITCHYARD

(This publication is adapted from the Unified Facilities Criteria of the United States government which are in the public domain, have been authorized for unlimited distribution and are not copyrighted.)

(Figures, tables and formulas in this publication may at times be a little difficult to read, but they are the best available. Do not purchase this publication if this limitation is unacceptable to you.)

1. TYPICAL VOLTAGE RATINGS AND SYSTEMS

1.1 VOLTAGES

1.1.1 GENERAL. Refer to ANSI Standard C84.1, Electric Power Systems and Equipment -Voltage Rating, for voltage ratings for 60 Hz electric power systems and equipment. In addition, the standard lists applicable motor and motor control nameplate voltage ranges up to nominal system voltages of 13.8 kV.

1.1.2 GENERATORS. Terminal voltage ratings for power plant generators depend on the size of the generators and their application. Generally, the larger the generator, the higher is the voltage. Generators for a power plant serving an installation will be in the range from 4160 volts to 13.8 kV to suit the size of the unit and primary distribution system voltage. Generators in this size range will be offered by the manufacturer in accordance with its design, and it would be difficult and expensive to get a different voltage rating. Insofar as possible, the generator voltage should match the distribution voltage to avoid the installation of a transformer between the generator and the distribution system.

1.1.3 POWER PLANT STATION SERVICE POWER SYSTEMS

a) Voltages for station service power supply within steam electric generating stations are related to motor size and, to a lesser extent, distances of cable runs. Motor sizes for draft fans and boiler feed pumps usually control the selection of the highest station service power voltage level. Rules for selecting motor voltage are not rigid but are based on relative costs. For instance, if there is only one motor larger than 200 hp and it is, say, only 300 hp, it might be a good choice to select this one larger motor for 460 volts so that the entire auxiliary power system can be designed at the lower voltage.

b) Station service power requirements for combustion turbine and internal combustion engine generating plants are such that 208 or 480 volts will be used.

1.1.4 DISTRIBUTION SYSTEM. The primary distribution system with central in-house generation should be selected in accordance with the owner's requirements.

1.2 STATION SERVICE POWER SYSTEMS

1.2.1 GENERAL. Two types of station service power systems are generally in use in steam electric plants and are discussed herein. They are designated as a common bus system and a unit system. The distinction is based on the relationship between the generating unit and the auxiliary transformer supplying power for its auxiliary equipment.

a) In the common bus system the auxiliary transformer will be connected through a circuit breaker to a bus supplied by a number of units and other sources so that the supply has no relationship to the generating unit whose auxiliary equipment is being served. In the unit system the auxiliary transformer will be connected solidly to the generator leads and is switched with the generator. In either case, the auxiliary equipment for each generating unit usually will be supplied by a separate transformer with appropriate interconnections between the secondary side of the transformers.

b) The unit type system has the disadvantage that its station service power requirements must be supplied by a startup transformer until the generating unit is synchronized with the system. This startup transformer also serves as the backup supply in case of transformer failure. This arrangement requires that the station service power supply be transferred from the startup source to the unit source with the auxiliary equipment in operation as a part of the procedure of starting the unit.

c) The advantages of the unit system are that it reduces the number of breakers required and that its source of energy is the rotating generating unit so that, in case of system trouble, the generating unit and its auxiliaries can easily be isolated from the rest of the system. The advantage of switching the generator and its auxiliary transformer as a unit is not very important, so the common bus system will normally be used.

1.2.2 COMMON BUS SYSTEM. In this system, generators will be connected to a common bus and the auxiliary transformers for all generating units will be fed from that common bus. This bus may have one or more other power sources to serve for station startup.

a) Figure 1 is a typical one-line diagram for such a system. This type system will be used for steam turbine or diesel generating plants with all station service supplied by two station service transformers with no isolation between auxiliaries for different generating units. It also will be used for gas turbine generating plants. For steam turbine generating plants the auxiliary loads for each unit in the plant will be isolated on a separate bus fed by a separate transformer. A standby transformer is included, and it serves the loads common to all units such as building services.

b) The buses supplying the auxiliaries for the several units shall be operated isolated to minimize fault current and permit use of lower interrupting rating on the feeder breakers. Provision shall be made for the standby transformer to supply any auxiliary bus.

1.2.3 UNIT TYPE SYSTEM. The unit type station service power system will be used for a steam electric or combustion turbine generating station serving a utility transmission network. It will not be, as a rule, used for a diesel generating station of any kind, since the station service power requirements are minimal. The distinguishing feature of a unit type station power system is that the generator and unit auxiliary transformer are permanently connected together at generator voltage and the station service power requirements for that generating unit, including boiler and turbine requirements, are normally supplied by the auxiliary transformer connected to the generator leads. This is shown in Figure 2. If the unit is to be connected to a system voltage that is higher than the generator voltage, the unit concept can be extended to include the step-up transformer by tying its low side solidly to the generator leads and using the high side breaker for synchronizing the generator to the system. This arrangement is shown in Figure 3.

1.2.4 STATION SERVICE SWITCHGEAR. A station service switchgear lineup will be connected to the low side of the auxiliary transformer. Air circuit breakers will be used for control of large auxiliary motors such as boiler feed pumps, fans, and circulating water pumps which use the highest station service voltage, and for distribution of power to various unit substations and motor control centers to serve the remaining station service requirements. Figure 4 is a typical one-line diagram of this arrangement. If the highest level of auxiliary voltage required is more than 480 volts, say 4.16 kV, the auxiliary switchgear air circuit breakers will only serve motors 250 hp and larger, and feeders to unit substations. Each unit substation will include a transformer to reduce voltage from the highest auxiliary power level to 480 volts together with air circuit breakers in a lineup for starting of motors 100 to 200 hp and for serving 480-volt motor control centers. The motor control centers will include combination starters and feeder breakers to serve motors less than 100 hp and other small auxiliary circuits such as power panels.

1.2.5 STARTUP AUXILIARY TRANSFORMER. In addition to the above items, the unit auxiliary type system will incorporate a "common" or "startup" arrangement which will consist of a startup and standby auxiliary transformer connected to the switchyard bus or other reliable source, plus a low voltage switchgear and motor control center arrangement similar to that described above for the unit auxiliary system. The common bus system may have a similar arrangement for the standby transformer.

a) This common system has three principal functions:

(1) To provide a source of normal power for power plant equipment and services which are common to all units; e.g., water treating system, coal and ash handling equipment, air compressors, lighting, shops, and similar items.

(2) To provide backup to each auxiliary power system segment if the transformer supplying that segment fails or is being maintained.

LEGEND

| | |
|------|--------------------------|
| □ | - H.V. CIRCUIT BREAKER |
| ⌋ | - L.V. CIRCUIT BREAKER |
| REG | - VOLTAGE REGULATOR |
| VM | - VOLTMETER |
| AM | - AMMETER |
| VARM | - VAR METER |
| WHM | - WATT-HOUR METER |
| SYN | - SYNCHROSCOPE |
| 87 | - DIFFERENTIAL RELAY |
| 51 | - TIME-OVERCURRENT RELAY |
| 46 | - NEG. SEQUENCE RELAY |
| 40 | - LOSS OF FIELD RELAY |
| 32 | - REVERSE POWER RELAY |
| WM | - WATTMETER |
| PF | - POWER FACTOR METER |

NOTE
 1. ONLY ONE NEUTRAL BREAKER SHOULD BE CLOSED

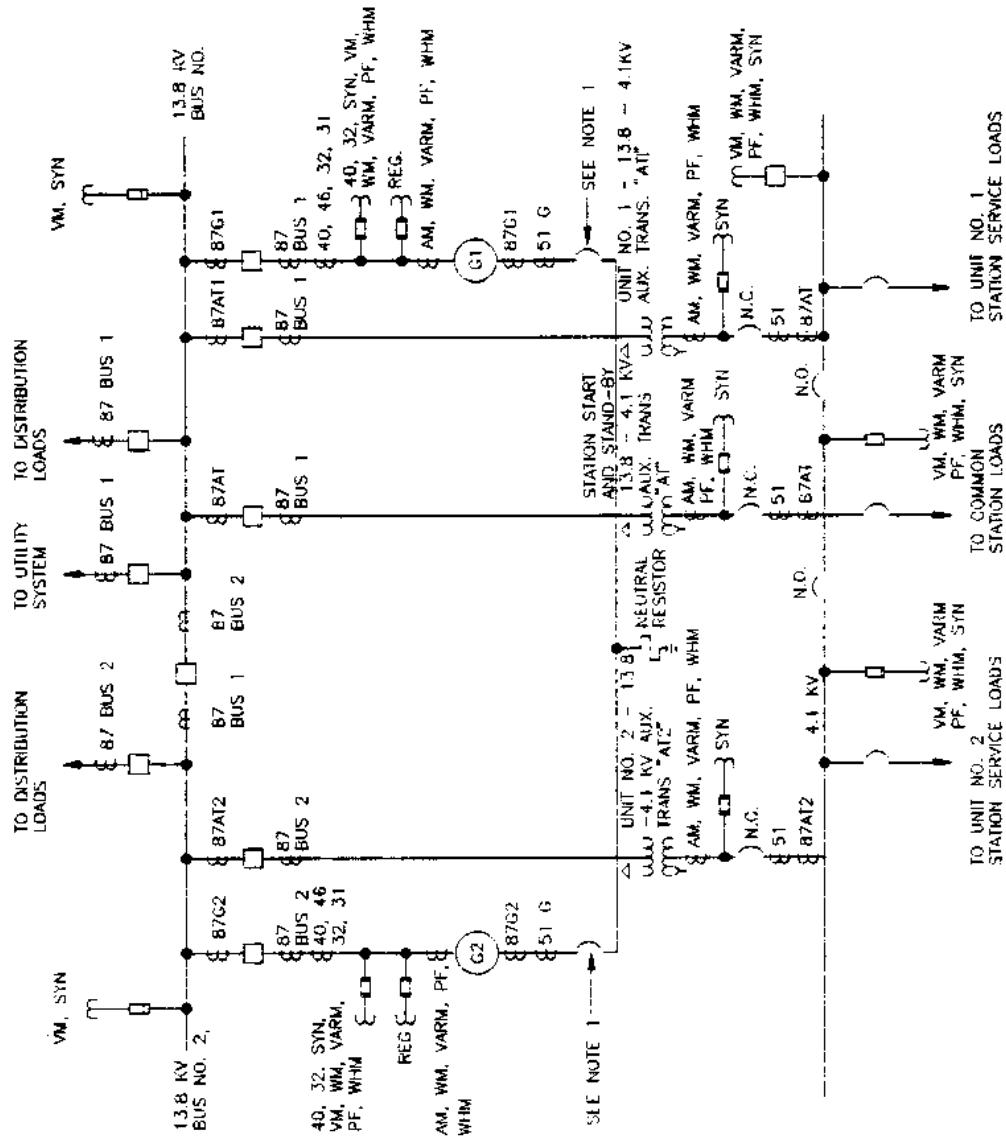

Figure 1

Station connections; 2-unit stations, common bus arrangement

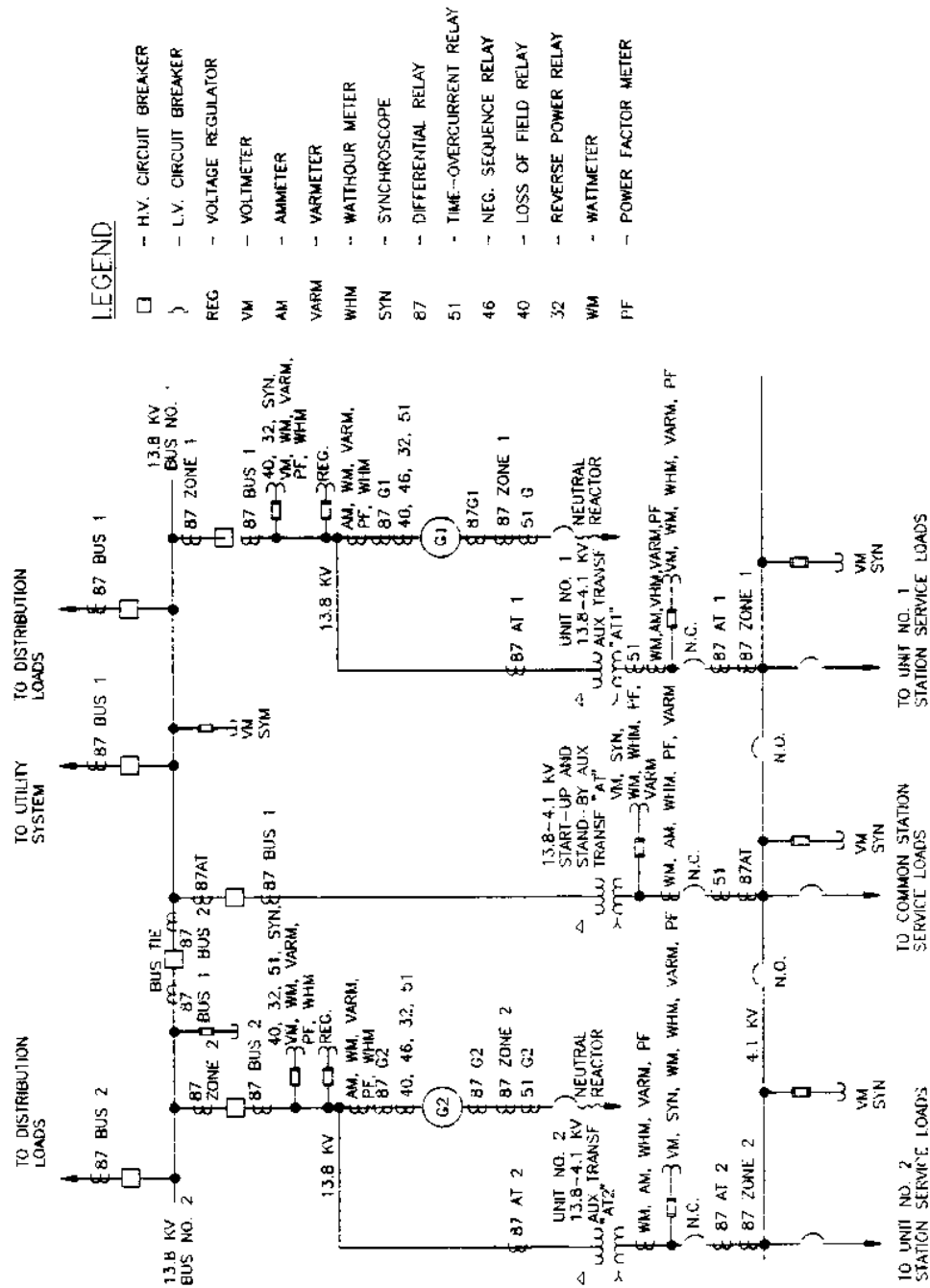

Figure 2

Station connections; 2-unit stations, unit arrangement at distribution voltage

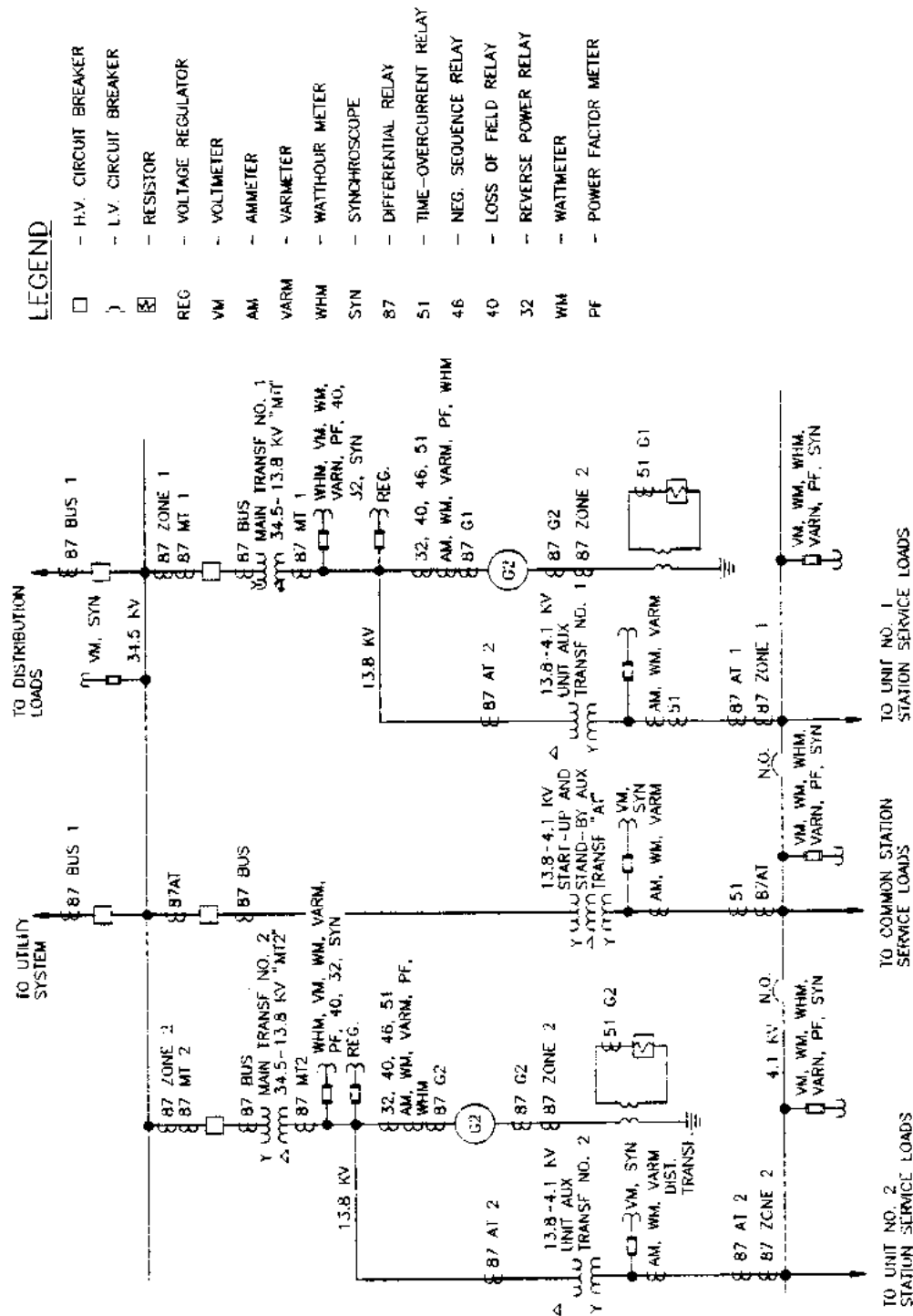

Figure 3

Station connections; 2-unit stations, unit arrangement at distribution, voltage higher than generation

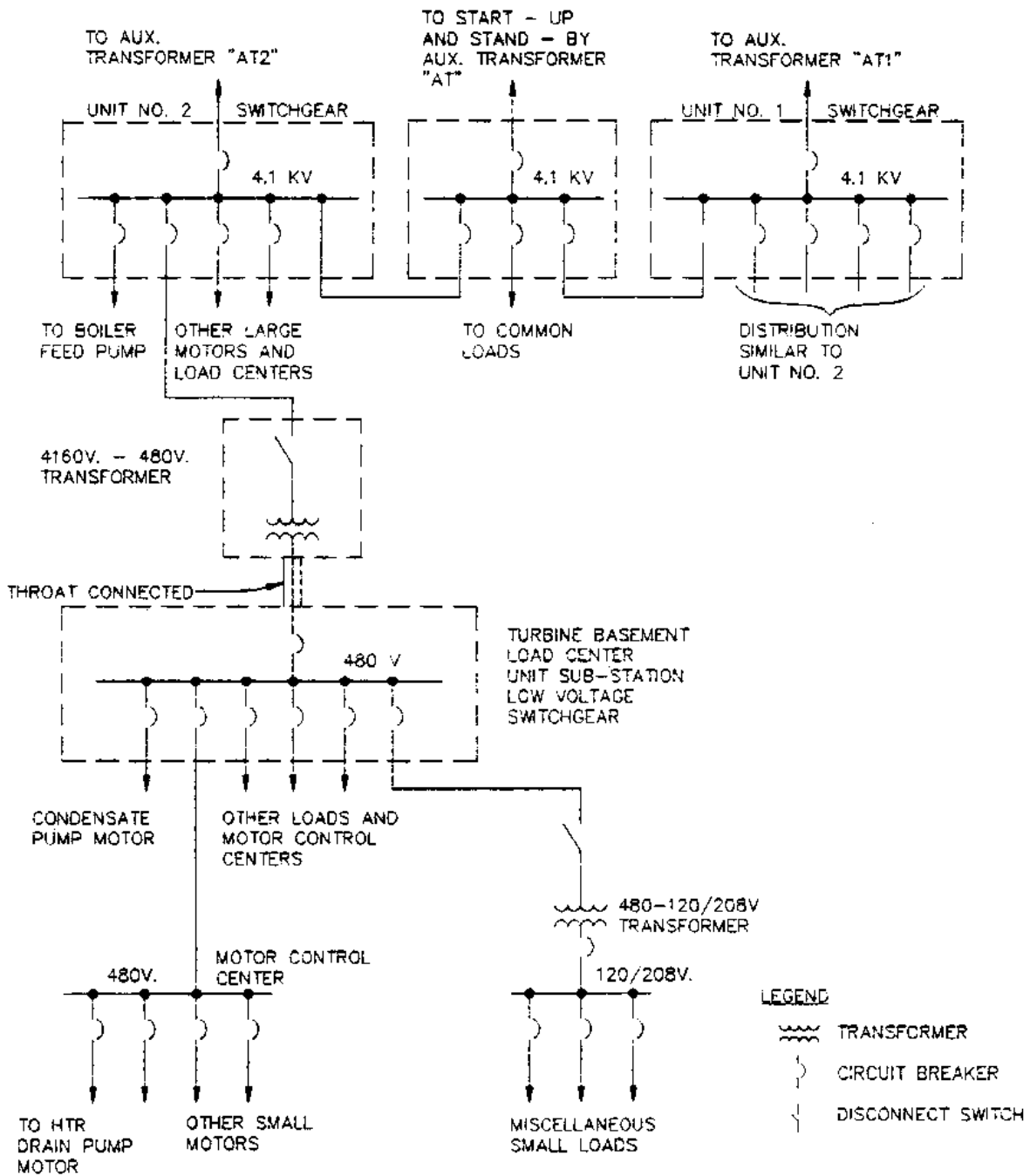

Figure 4
One line diagram, typical station service power systems

(3) In the case of the unit system, to provide startup power to each unit auxiliary power system until the generator is up to speed and voltage and is synchronized with the distribution system.

b) The startup and standby transformer and switchgear will be sized to accomplish the above three functions and, in addition, to allow for possible future additions to the plant. Interconnections will be provided between the common and unit switchgear. Appropriate interlocks will be included, so that no more than one auxiliary transformer can feed any switchgear bus at one time.

2. GENERATORS

2.1 GENERAL TYPES AND STANDARDS

2.1.1 TYPE. Generators for power plant service can be generally grouped according to service and size.

a) Generators for steam turbine service rated 5,000-32,000 kVA, are revolving field, non-salient, two-pole, totally enclosed, air-cooled with water cooling for air coolers, direct connected, 3,600 rpm for 60 Hz frequency (sometimes connected through a gear reducer up to 10,000 kVA or more). Self-ventilation is provided for generators larger than 5,000 kVA by some manufacturers, but this is not recommended for steam power plant service.

b) Similar generators rated 5,000 kVA and below are revolving field, nonsalient or salient pole, self-ventilated, open drip-proof type, sometimes connected through a gear reducer to the turbine with the number of poles dependent on the speed selected which is the result of an economic evaluation by the manufacturer to optimize the best combination of turbine, gear, and generator.

c) Generators for gas turbine service are revolving field, nonsalient or salient pole, self-ventilated, open drip-proof type, sometimes connected through a gear reducer, depending on manufacturer's gas turbine design speed, to the gas turbine power takeoff shaft. Non-salient pole generators are two-pole, 3,600 rpm for 60Hz, although manufacturers of machines smaller than 1,500 kVA may utilize 1,800 rpm, four-pole, or 1,200 rpm, six-pole, salient pole generators. Generators may be obtained totally enclosed with water cooling, if desired, because of high ambient temperatures or polluted atmosphere.

d) Generators for diesel service are revolving field, salient pole, air cooled, open type, direct connected, and with amortisseur windings to dampen pulsating engine torque. Number of poles is six or more to match low speeds typical of diesels.

2.1.2 STANDARDS. Generators shall meet the requirements of ANSI C50.10, C50.13, and C50.14. These are applicable as well as the requirements of National Electrical Manufacturers Association (NEMA) SM 23, Steam Turbines for Mechanical Drive Service, and SM 24, Land Based Steam Turbine Generator sets 0 to 33,000 KW.

a) ANSI C84.1 designates standard voltages as discussed in Section 1.

b) Generator kVA rating for steam turbine generating units is standardized as a multiplier of the turbine kW rating. Turbine rating for a condensing steam turbine with controlled extraction for feedwater heating is the kW output at design initial steam conditions, 3.5 inches Hg (12 kPa) absolute exhaust pressure, three percent cycle makeup, and all feedwater heaters in service. Turbine rating for a noncondensing turbine without controlled or uncontrolled extraction is based on output at design initial steam conditions and design exhaust pressure. Turbine standard ratings for automatic extraction units are based on design initial steam conditions and exhaust pressure with zero extraction while maintaining rated extraction pressure. However, automatic extraction turbine ratings are complicated by the unique steam extraction requirements for each machine specified. For air-cooled generators up to 15,625 kVA, the multiplier is 1.25 times the turbine rating, and for 18,750 kVA air-cooled and hydrogen-cooled generators, the multiplier is 1.20. These ratings are for water-cooled generators with 95 degrees F (35 degrees C) maximum inlet water to the generator air or hydrogen coolers. Open, self-ventilated generator rating varies with ambient air temperature; standard rating usually is at 104 degrees F (40 degrees C) ambient.

c) Generator ratings for gas turbine generating units are selected in accordance with ANSI Standards which require the generator rating to be the base capacity which, in turn, must be equal to or greater than the base rating of the turbine over a specified

range of inlet temperatures. Non-standard generator ratings can be obtained at an additional price.

d) Power factor ratings of steam turbine driven generators are 0.80 for ratings up to 15,625 kVA and 0.85 for 17,650 kVA air-cooled and 25,600 kVA to 32,000 kVA air/water-cooled units. Standard power factor ratings for gas turbine driven air-cooled generators usually are 0.80 for machines up to 9,375 kVA and 0.90 for 12,500 to 32,000 kVA. Changes in air density, however, do not affect the capability of the turbine and generator to the same extent so that kW based on standard conditions and generator kVA ratings show various relationships. Power factors of large hydrogen cooled machines are standardized at 0.90. Power factor for salient pole generators is usually 0.80. Power factor lower than standard, with increased kVA rating, can be obtained at an extra price.

e) Generator short circuit ratio is a rough indication of generator stability; the higher the short circuit ratio, the more stable the generator under transient system load changes or faults. However, fast acting voltage regulation can also assist in achieving generator stability without the heavy expense associated with the high cost of building high short circuit ratios into the generator. Generators have standard short circuit ratios of 0.58 at rated kVA and power factor. If a generator has a fast acting voltage regulator and a high ceiling voltage static excitation system, this standard short circuit ratio should be adequate even under severe system disturbance conditions. Higher short circuit ratios are available at extra cost to provide more stability for unduly fluctuating loads which may be anticipated in the system to be served.

f) Maximum winding temperature, at rated load for standard generators, is predicated on operation at or below a maximum elevation of 3,300 feet; this may be upgraded for higher altitudes at an additional price.

2.2 FEATURES AND ACCESSORIES. The following features and accessories are available in accordance with NEMA standards SM 12 and SM 13 and will be specified as applicable for each generator:

2.2.1 VOLTAGE VARIATIONS. Unit will operate with voltage variations of plus or minus 5 percent of rated voltage at rated kVA, power factor and frequency, but not necessarily in accordance with the standards of performance established for operation at rated voltage; i.e., losses and temperature rises may exceed standard values when operation is not at rated voltage.

2.2.2 THERMAL VARIATIONS

a) Starting from stabilized temperatures and rated conditions, the armature will be capable of operating, with balanced current, at 130 percent of its rated current for 1 minute not more than twice a year; and the field winding will be capable of operating at 125 percent of rated load field voltage for 1 minute not more than twice a year.

b) The generator will be capable of withstanding, without injury, the thermal effects of unbalanced faults at the machine terminals, including the decaying effects of field current and DC component of stator current for times up to 120 seconds, provided the integrated product of generator negative phase sequence current squared and time does not exceed 30. Negative phase sequence current is expressed in per unit of rated stator current, and time in seconds. The thermal effect of unbalanced faults at the machine terminals includes the decaying effects of field current where protection is provided by reducing field current (such as with an exciter field breaker or equivalent) and DC component of the stator current.

2.2.3 MECHANICAL WITHSTAND. Generator will be capable of withstanding, without mechanical injury, any type of short circuit at its terminals for times not exceeding its short time thermal capabilities at rated kVA and power factor with 5 percent over rated voltage, provided that maximum phase current is limited externally to the maximum

current obtained from the three-phase fault. Stator windings must withstand a normal high potential test and show no abnormal deformation or damage to the coils and connections.

2.2.4 EXCITATION VOLTAGE. Excitation system will be a wide range stabilized to permit stable operation down to 25 percent of rated excitation voltage on manual control. Excitation ceiling voltage on manual control will not be less than 120 percent of the rated exciter voltage when operating with a load resistance equal to the generator field resistance, and excitation system will be capable of supplying this ceiling voltage for not less than 1 minute. These criteria, as set for manual control, will permit operation when on automatic control. Exciter response ratio as defined in ANSI/IEEE 100, Dictionary of Electrical & Electronic Terms, will not be less than 0.50.

2.2.5 WAVE SHAPE. Deviation factor of the open circuit terminal voltage wave will not exceed 10 percent.

2.2.6 TELEPHONE INFLUENCE FACTOR. The balanced telephone influence factor (TIF) and the residual component TIF will meet the applicable requirements of ANSI C50.13.

2.3 EXCITATION SYSTEMS. Rotating commutator exciters as a source of DC power for the AC generator field generally have been replaced by silicon diode power rectifier systems of the static or brushless type.

a) A typical brushless system includes a rotating permanent magnet pilot exciter with the stator connected through the excitation switchgear to the stationary field of an AC exciter with rotating armature and a rotating silicon diode rectifier assembly, which in turn is connected to the rotating field of the generator. This arrangement eliminates both the commutator and the collector rings. Also, part of the system is a solid state automatic voltage regulator, a means of manual voltage regulation, and necessary control devices for mounting on a remote panel. The exciter rotating parts and the

diodes are mounted on the generator shaft; viewing during operation must utilize a strobe light.

b) A typical static system includes a three-phase excitation potential transformer, three single-phase current transformers, an excitation cubicle with field breaker and discharge resistor, one automatic and one manual static thyristor type voltage regulators, a full wave static rectifier, necessary devices for mounting on a remote panel, and a collector assembly for connection to the generator field.

3. GENERATOR LEADS AND SWITCHYARD

3.1 GENERAL. The connection of the generating units to the distribution system can take one of the following patterns:

a) With the common bus system, the generators are all connected to the same bus with the distribution feeders. If this bus operates at a voltage of 4.16 kV, this arrangement is suitable up to approximately 10,000 kVA. If the bus operates at a voltage of 13.8 kV, this arrangement is the best for stations up to about 25,000 or 32,000 kVA. For larger stations, the fault duty on the common bus reaches a level that requires more expensive feeder breakers, and the bus should be split.

b) The bus and switchgear will be in the form of factory fabricated metal clad switchgear. For plants with multiple generators and outgoing circuits, the bus will be split for reliability using a bus tie breaker to permit separation of approximately one-half of the generators and lines on each side of the split.

c) A limiting factor of the common type bus system is the interrupting capacity of the switchgear. The switchgear breakers will be capable of interrupting the maximum possible fault current that will flow through them to a fault. In the event that the possible fault current exceeds the interrupting capacity of the available breakers, a synchronizing bus with current limiting reactors will be required. Switching arrangement selected will be adequate to handle the maximum calculated short circuit currents which can be developed under any operating routine that can occur. All possible sources of fault current; i.e., generators, motors, and outside utility sources, will be considered when calculating short circuit currents. In order to clear a fault, all sources will be disconnected. Figure 5 shows, in a simplified single line format, a typical synchronizing bus arrangement. The interrupting capacity of the breakers in the switchgear for each set of generators is limited to the contribution to a fault from the generators connected to that bus section plus the contribution from the synchronizing bus and large (load)

motors. Since the contribution from generators connected to other bus sections must flow through two reactors in series, fault current will be reduced materially.

d) If the plant is 20,000 kVA or larger, and the area covered by the distribution system requires distribution feeders in excess of 2 miles, it may be advantageous to connect the generators to a higher voltage bus and feed several distribution substations from that bus with step-down substation transformers at each distribution substation as shown in Figure 3.

e) The configuration of the high voltage bus will be selected for reliability and economy. Alternative bus arrangements include main and transfer bus, ring bus, and breaker and a half schemes. The main and transfer arrangement, shown in Figure 6, is the lowest cost alternative but is subject to loss of all circuits due to a bus fault. The ring bus arrangement, shown in Figure 7, costs only slightly more than the main and transfer bus arrangement and eliminates the possibility of losing all circuits from a bus fault, since each bus section is included in the protected area of its circuit. Normally it will not be used with more than eight bus sections because of the possibility of simultaneous outages resulting in the bus being split into two parts. The breaker and a half arrangement, shown in Figure 8, is the highest cost alternative and provides the highest reliability without limitation on the number of circuits.

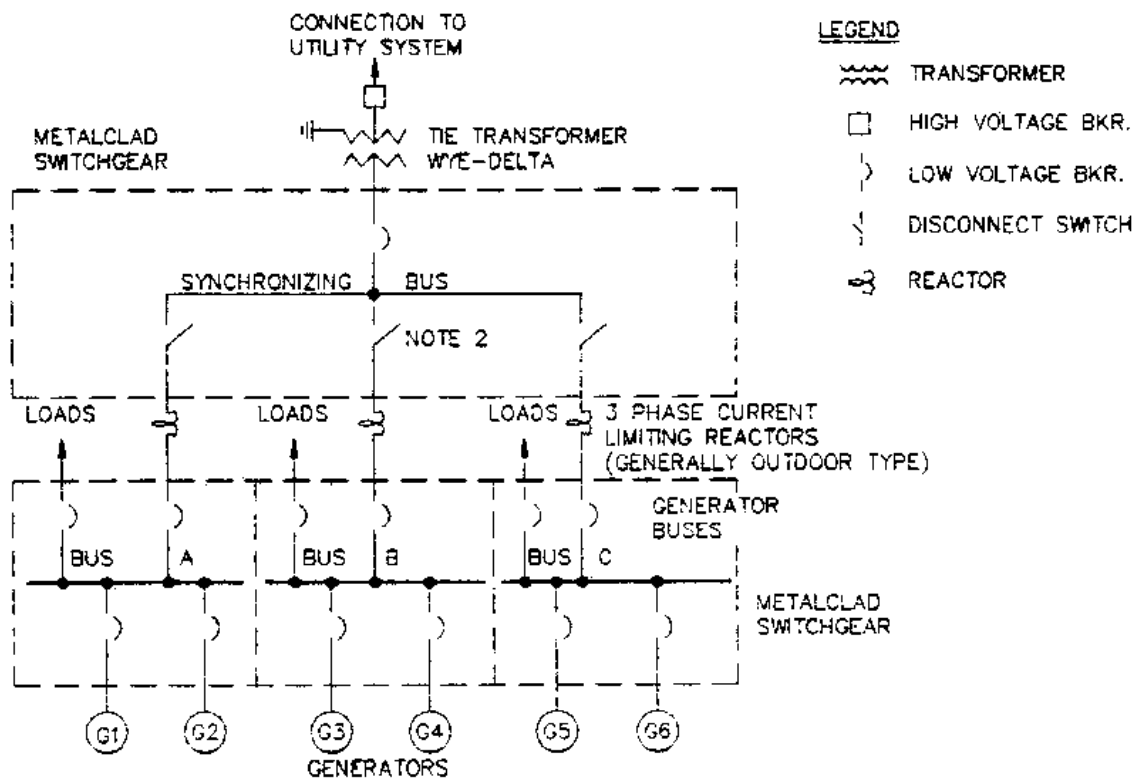

MULTIPLE GENERATORS CONNECTED TO COMMON BUSES (TWO GENs. PER BUS) WITH FEEDS TO DISTRIBUTION SYSTEM AT GENERATOR VOLTAGE

NOTE 1. IF NO UTILITY CONNECTION IS REQUIRED, THE SYNCHRONIZING BUS STILL FUNCTIONS TO CONNECT BUSES A, B, AND C.

NOTE 2. IN DRAWOUT TYPE METALCLAD SWITCHGEAR THESE DISCONNECTS CAN BE DUMMY BREAKERS TO PERMIT INSPECTION AND MAINTENANCE OF REACTORS AT MINIMUM COST. CIRCUIT BREAKERS ARE NOT REQUIRED.

Figure 5

Typical synchronizing bus

3.2 GENERATOR LEADS

3.2.1 CABLE

a) Connections between the generator and switchgear bus where distribution is at generator voltage, and between generator and step up transformer where distribution is

at 34.5 kV and higher, will be by means of cable or bus duct. In most instances more than one cable per phase will be necessary to handle the current up to a practical maximum of four conductors per phase. Generally, cable installations will be provided for generator capacities up to 25 MVA. For larger units, bus ducts will be evaluated as an alternative.

b) The power cables will be run in a cable tray, separate from the control cable tray, in steel conduit suspended from ceiling or on wall hangers, or in ducts, depending on the installation requirements.

c) Cable terminations will be made by means of potheads where lead covered cable is applied, or by compression lugs where neoprene or similarly jacketed cables are used. Stress cones will be used at 4.16 kV and above.

d) For most applications utilizing conduit, cross-linked polyethylene with approved type filler or ethylene-propylene cables will be used. For applications where cables will be suspended from hangers or placed in tray, armored cable will be used to provide physical protection. If the cable current rating does not exceed 400 amperes, the three phases will be triplexed; i.e., all run in one steel armored enclosure. In the event that single-phase cables are required, the armor will be nonmagnetic.

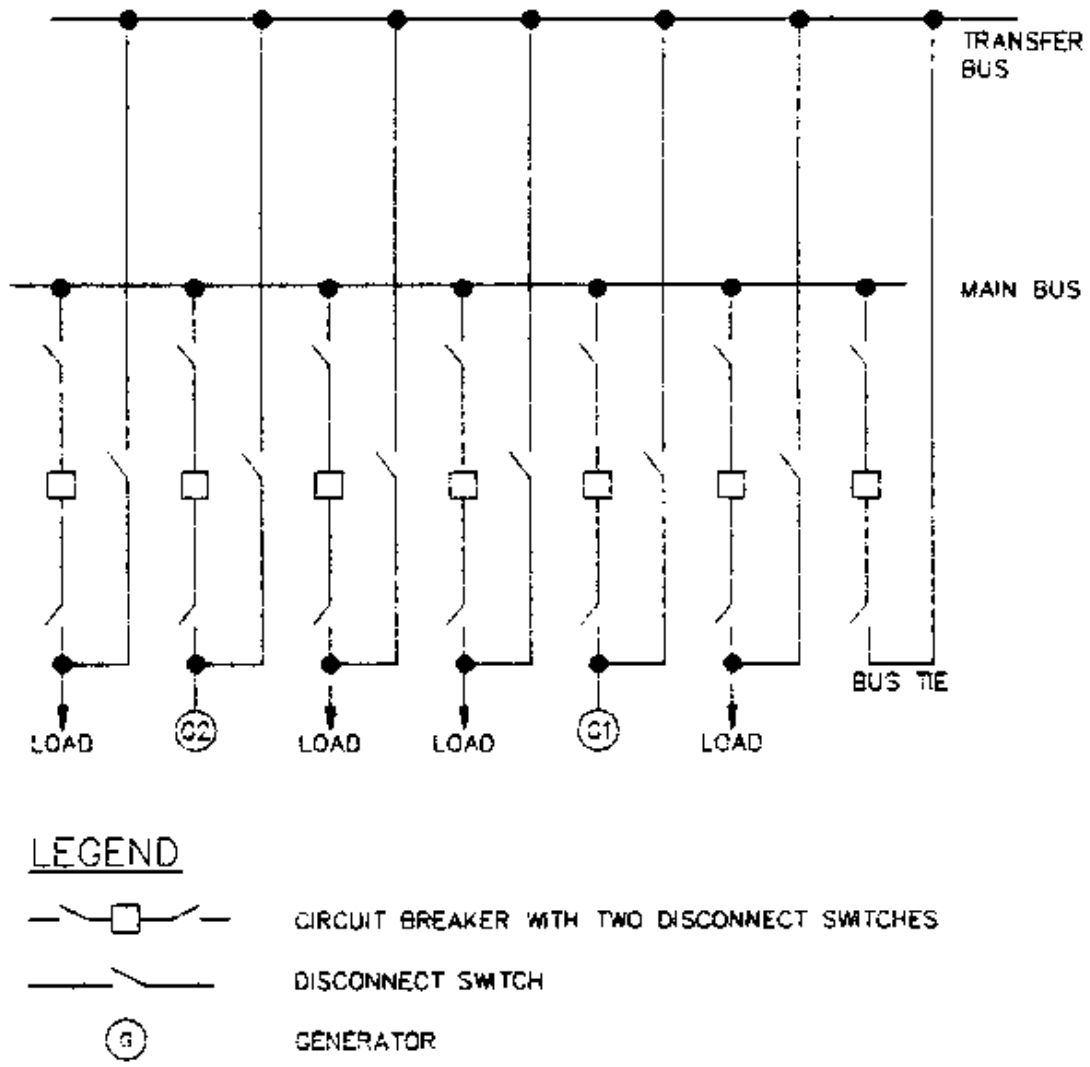
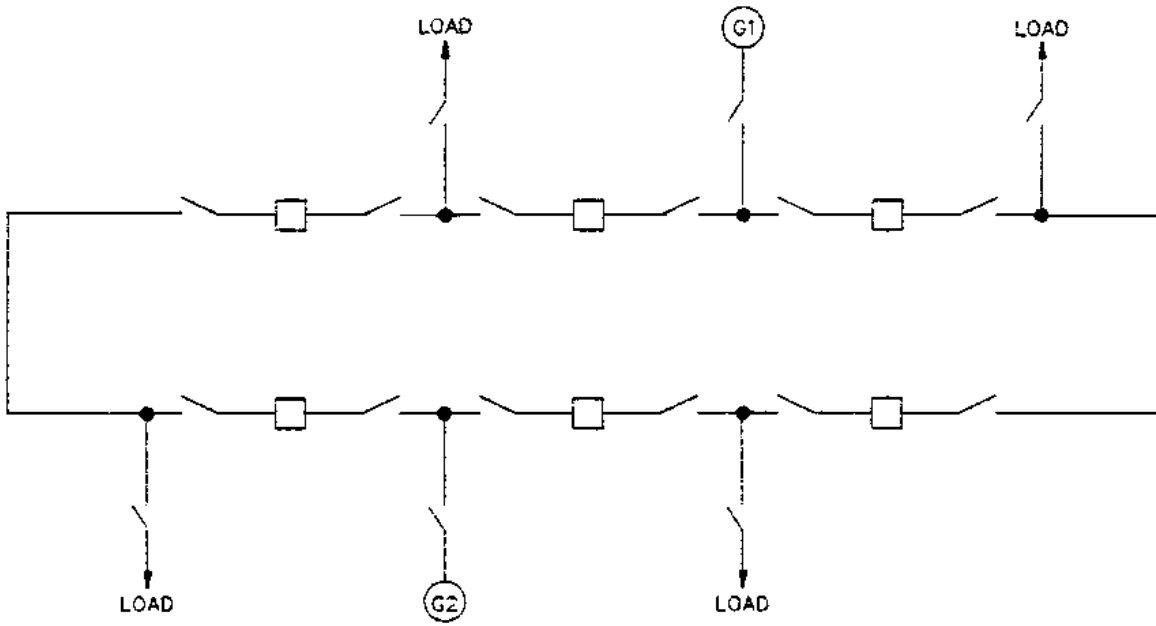

Figure 6
 Typical main and transfer bus



LEGEND



- 
CIRCUIT BREAKER WITH TWO DISCONNECT SWITCHES
- 
DISCONNECT SWITCH
- 
GENERATOR

Figure 7
Typical ring bus



LEGEND

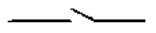

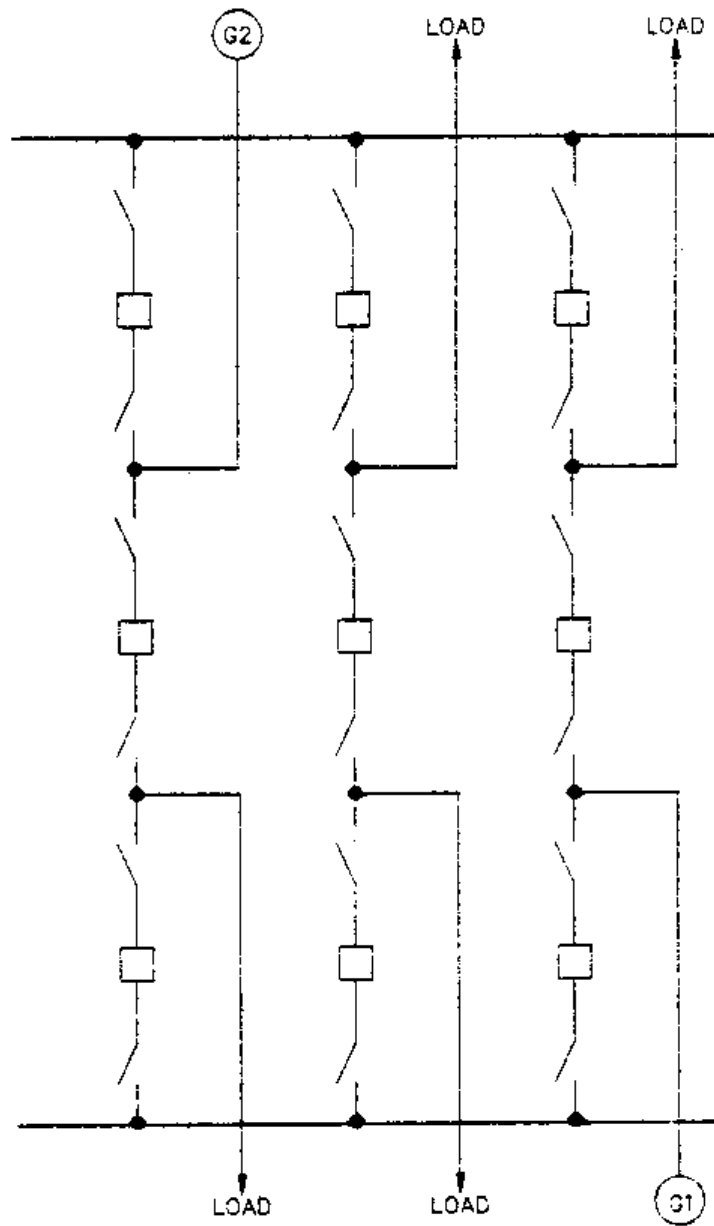
- 
CIRCUIT BREAKER WITH TWO DISCONNECT SWITCHES
- 
DISCONNECT SWITCH
- 
GENERATOR

Figure 8
Typical breaker and a half bus

e) In no event should the current carrying capacity of the power cables emanating from the generator be a limiting factor on turbine generator output. As a rule of thumb, the cable current carrying capacity will be at least 1.25 times the current associated with kVA capacity of the generator (not the kW rating of the turbine).

3.2.2 SEGREGATED PHASE BUS

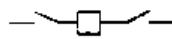
a) For gas turbine generator installations the connections from the generator to the side wall or roof of the gas turbine generator enclosure will have been made by the manufacturer in segregated phase bus configuration. The three-phase conductors will be flat copper bus, either in single or multiple conductor per phase pattern. External connection to switchgear or transformer will be by means of segregated phase bus or cable. In the segregated phase bus, the three bare bus-phases will be physically separated by nonmagnetic barriers with a single enclosure around the three buses.

b) For applications involving an outdoor gas turbine generator for which a relatively small lineup of outdoor metal clad switchgear is required to handle the distribution system, a segregated phase bus will be used. For multiple gas turbine generator installations, the switchgear will be of indoor construction and installed in a control/switchgear building. For these installations, the several generators will be connected to the switchgear via cables.

c) Segregated bus current ratings may follow the rule of thumb set forth above for generator cables, but final selection will be based on expected field conditions.

3.2.3 ISOLATED PHASE BUS

a) For steam turbine generator ratings of 25 MVA and above, the use of isolated phase bus for connection from generator to step up transformer will be used. At such generator ratings, distribution seldom is made at generator voltage. An isolated phase bus system, utilizing individual phase copper or aluminum, hollow square or round bus

on insulators in individual nonmagnetic bus enclosures, provides maximum reliability by minimizing the possibility of phase-to-ground or phase-to-phase faults.

b) Isolated phase bus current ratings should follow the rule of thumb set forth above for generator cables.